

Setting Up the CyberData Speakers with Linksys SPA-9000

1.0 Setting Up the Linksys SPA-9000

To set up the Linksys SPA-9000:

- 1.1 Run a Cat 5 cable from a POE/Ethernet hub to the **Internet** port on the SPA-9000.
- 1.2 Run a second Cat 5 cable from a PoE/Ethernet hub to the **Ethernet** port on the SPA-9000.
- 1.3 Plug in a computer/laptop, a Linksys phone, and a CyberData speaker to the PoE/Ethernet hub.
- 1.4 Adjust the IP address of the computer/laptop so that it is on the same network as the SPA-9000 (192.168.0.X).
- 1.5 Enter the IP address of SPA-9000 in a browser (192.168.0.1/admin/voice/advanced).
- 1.6 Under **Voice** click on the **SIP** tab.
- 1.7 In the **PBX** parameters section, select **WAN**.
- 1.8 Click on **submit all changes**.
- 1.9 Click on the **Router** tab.
- 1.10 Click on the **WAN Setup** tab.
- 1.11 From the **Connection Type** drop-down menu, select **Static IP**.
- 1.12 In the **Static IP** section, fill out the **IP address**, **Netmask** and **Gateway** fields.
- 1.13 Go to **Router => LAN Setup** and set an IP address that is on a different subnet than the WAN address.
- 1.14 Select **submit all changes**.

2.0 Setting up the Speaker for SIP

To set up the speaker for SIP:

- 2.1 Pull up the web-based configuration for the speaker and click on **SIP settings**.
- 2.2 Enter the username (usually an extension number) and password.
- 2.3 Enter the static IP address that is in the **WAN setup** of the SPA-9000 as the SIP server address.
- 2.4 Change the **remote SIP** port to **6060**.
- 2.5 Save the settings and reboot the speaker.
- 2.6 Send a page to the speaker by entering the extension number (username) of the speaker at the dial-tone.

Figure 1. Linksys—SIP Diagram

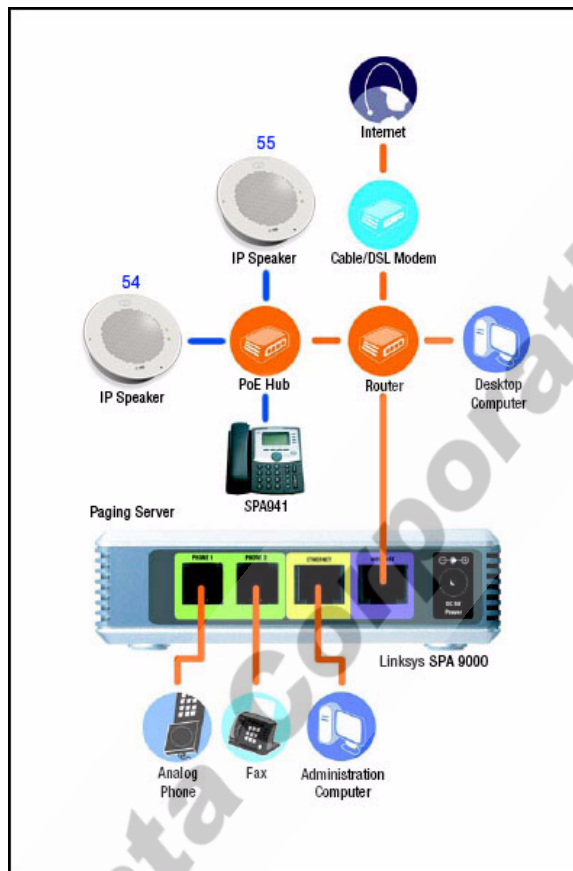

3.0 Setting up the Speaker for Multicast

To set up the speaker for Multicast:

- 3.1 If you are using CyberData speakers as MGROUPS, complete step 1.1 through step 1.13.
- 3.2 Go to **Voice => SIP** and make a note of the multicast address and port number for **page groups** (default is 224.168.168.168, port 34567).
- 3.3 Go to the **Speaker Setup** on the webpage for the speaker and select **MGROUPS** and **DHCP**.
- 3.4 After the speaker reboots, get the IP address by activating the DTMF switch on the speaker to announce the new IP address. Enter this new address in the browser to access the speaker's web page.
- 3.5 Select the **MGROUPS** tab and enter the same multicast address and port number in step 3.1.
- 3.6 Save the settings and reboot the speaker.
- 3.7 Send a page to the speaker by dialing ***96** on the Linksys phone and then selecting the **dir** menu.
- 3.8 Select the **corporate directory** menu.

3.9 Select **page groups** as the page target (see [Figure 2](#)).

Figure 2. Linksys—Multicast Diagram

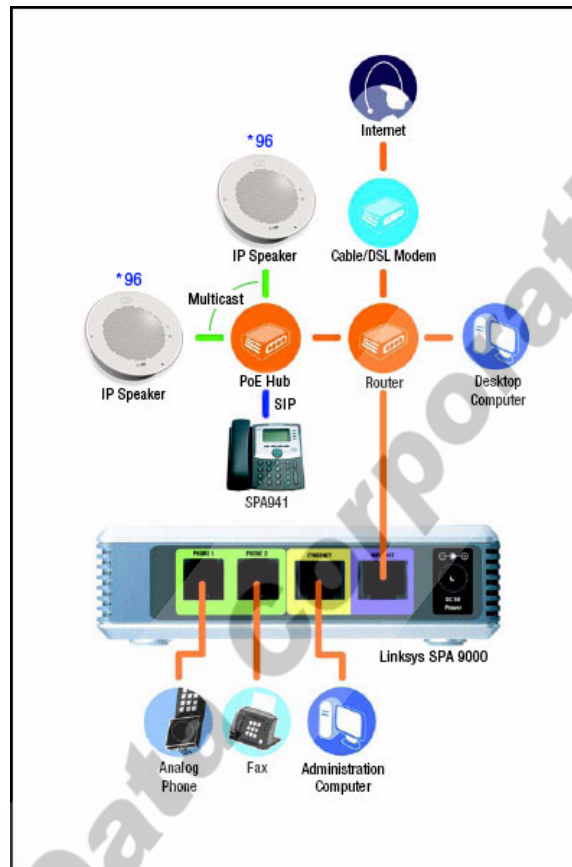

4.0 Setting up the Paging Server

To set up the paging server:

- 4.1 If you are connecting the CyberData Paging Server product to CyberData speakers so that you can have more than one paging zone ([Figure 3](#)), complete step [1.1](#) through step [1.13](#).
- 4.2 Go to the web configuration page for the Paging Server and set it up as a SIP endpoint with the following:
 - Username (extension number)
 - Password (make sure this matches what you have in [step 2.2](#))
 - SIP server address ([step 1.5](#)). Multicast address and port number combination
 - DTMF two digit tone for each paging zone

Figure 3. Linksys—Paging Server Diagram

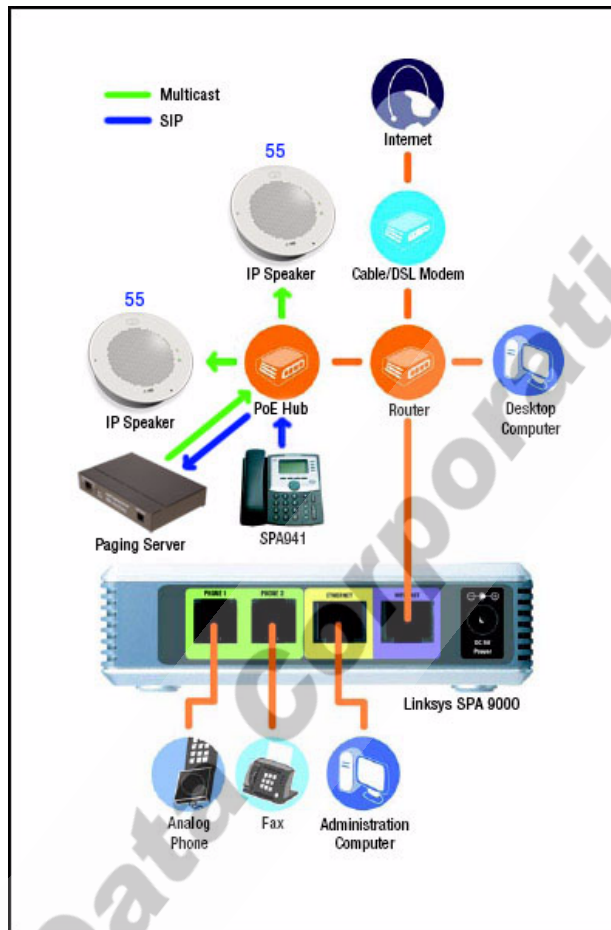

4.3 Go to the web configuration for the speaker and select **MGROUPS**.

4.4 In the **MGROUPS Setup** page, match the multicast address and port number combination that you put in the Paging Server for the paging zone that you want for the speaker.

4.5 Dial the Paging Server's extension from the SIP phone.

Note Enter a two-digit DTMF tone for the paging zone and initiate the page.